

# MICHELE POMPILIO

S G R

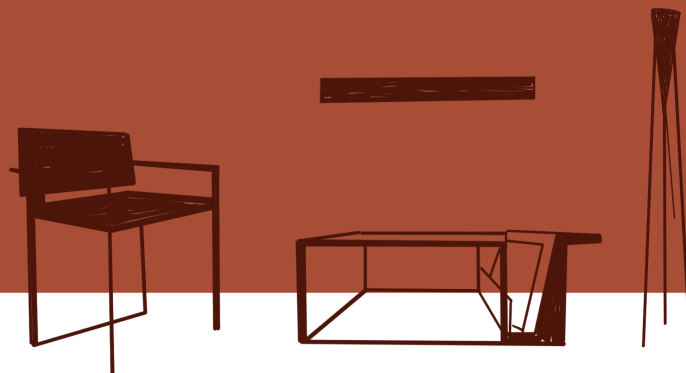

Collection 2025

*The collection weaves together a series of drawings that mark the passage of time. The earliest ones, traced by my father's hand, stand as silent witnesses to the changing seasons, now interwoven with my more recent creations. The result is a harmony of materials, shapes, and colors.*

*Sons become custodians of their fathers' work, ferrymen of ancient values towards new worlds.*

*Each piece is born in San Giovanni Rotondo, Italy, with deep respect for materials, places, and people.*

# Overview

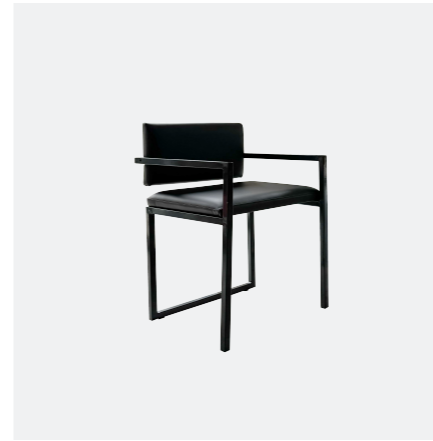

**Numa**  
armchair

design  
2024

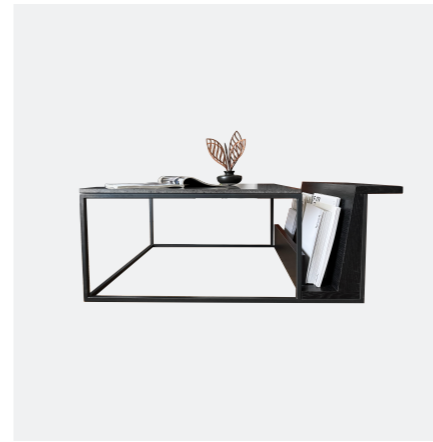
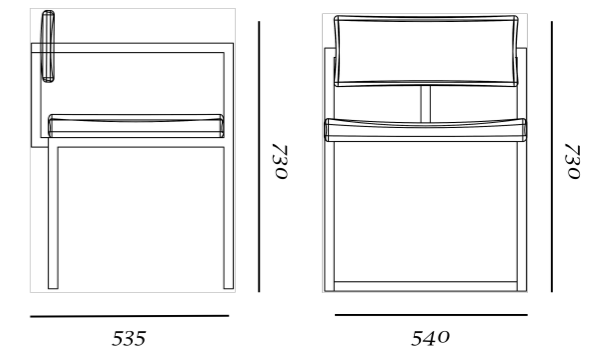

**Slitta**  
low table

design  
2018

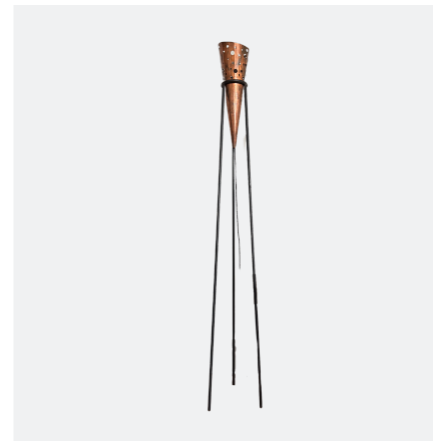
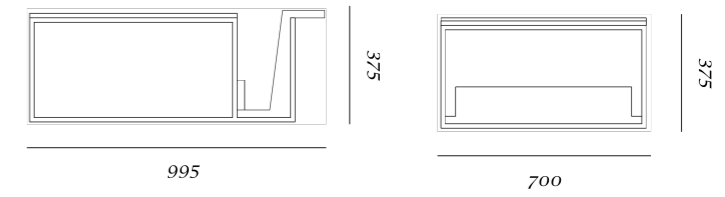

**Cartoccio**  
floor lamp

design  
1999

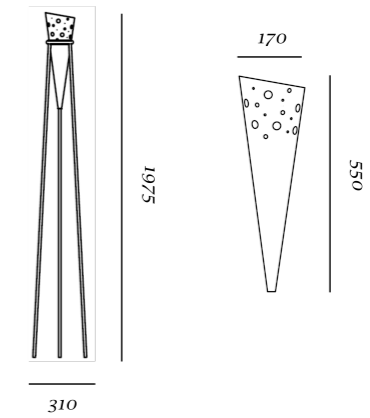

**Tunnel**  
wall lamp

design  
1997

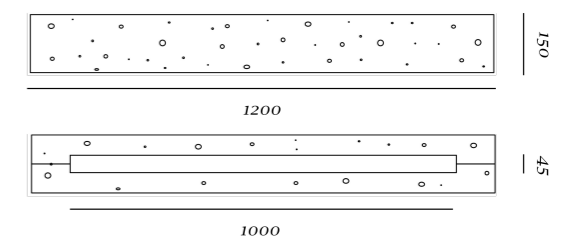



**Numa** armchair  
design 2024

**Numa** armchair  
design 2024





**Numa** armchair  
design 2024



**Numa** armchair  
design 2024





**Slitta** low table  
design 2018



**Slitta** low table  
design 2018



**Slitta** low table  
design 2018



**Slitta** low table  
design 2018







**Tunnel** wall lamp  
design 1997



**Tunnel** wall lamp  
design 1997

**Cartoccio** floor lamp  
design 1999



**Tunnel** wall lamp  
design 1997

**Cartoccio** floor lamp  
design 1999



**Cartoccio** floor lamp  
design 1999



**Cartoccio** floor lamp  
design 1999



# Credits

Collection by  
**Michele Pompilio**  
Via Sant'Agata 24A  
71013 San Giovanni Rotondo (FG), Italy  
[michelepompilio.com](http://michelepompilio.com)

Graphic Design  
**Mirco Timperanza**

Photography  
**Salvatore Palladino**

Cover Design  
**Nadia Romero Marchesini**

All rights reserved  
No part of this publication may be reproduced, distributed, or transmitted  
in any form or by any means, without the prior written permission of the  
publisher.  
Michele Pompilio reserves the right to introduce any changes to its own  
models, without prior notice.

© Michele Pompilio 2025

